



## UX.4000 : 14 bit A/D Digitizer / Oscilloscope, up to 50 MS/s

- PXI 3U / CompactPCI 3U format
- Fastest 14 bit A/D converter board
- Models with 20 MS/s or 50 MS/s
- 1 or 2 channels acquisition
- Simultaneous sampling on all channels
- 6 input ranges:  $\pm 200$  mV up to  $\pm 10$  V
- Up to 64 MSample memory
- FIFO mode
- Window and pulsewidth trigger
- Input offset up to  $\pm 200\%$
- Synchronization possible
- Windows program SBench 5.x included



### Product range overview

The UltraFast PXI cards are based on more than 16 years design experience. The cards are high-quality, low-noise PC-based instruments that have deeper memory and more flexibility than traditional oscilloscopes and transient recorders.

Model	1 channel	2 channels	4 channels
UX.4020	20 MS/s		
UX.4021	20 MS/s	20 MS/s	
UX.4030	50 MS/s		
UX.4031	50 MS/s	50 MS/s	

### Software/Drivers

A large number of drivers and examples are delivered with the board or are available as an option:

- Windows 98/ME/NT/2000/XP - drivers
- Linux - drivers
- SBench 5.2
- Streaming Software SPviewIT 6.2 (as option)
- Visual C++/Borland C++ Builder examples
- Borland Delphi examples
- Microsoft Visual Basic examples
- Microsoft Excel examples
- LabWindows/CVI examples
- FlexPro support with SBench
- LabVIEW - drivers (as option)
- DASyLab - drivers (as option)
- MATLAB - drivers (as option)
- Agilent VEE - drivers (as option)

### General Information

The UX.4000 cards are most suitable for applications that need a maximum signal dynamic range as they have a resolution 4 times higher than 12 bit boards.

Each channel has its own A/D converter so there is no phase error between channels. The voltage range, signal offset and input impedance can be programmed for each channel to match a wide variety of signal sources.

Data is written in the internal 8 MSamples up to 64 MSample large memory. This memory can also be used as a FIFO buffer so that data can be transferred on-line directly into the PC RAM or to hard disk.

### Hardware block diagram

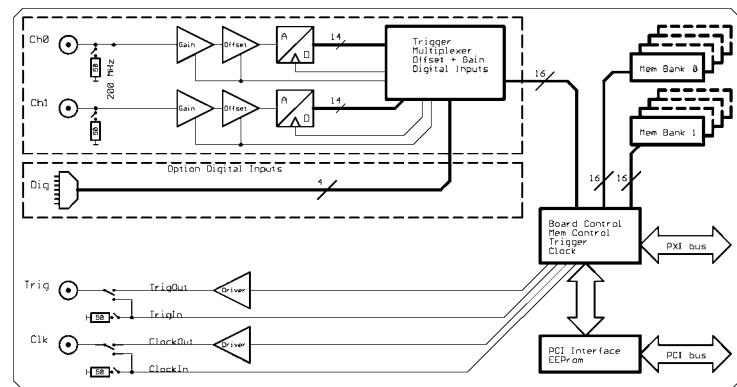

### Software programmable parameters

Sampling rate	1 kS/s to max sampling rate, external clock, ref clock, PXI clock
Input Range	$\pm 200$ mV, $\pm 500$ mV, $\pm 1$ V, $\pm 2$ V, $\pm 5$ V, $\pm 10$ V
Input impedance	50 Ohm / 1 MOhm
Input Offset	$\pm 200\%$ in steps of 1%
Clock mode	internal PLL, internal quartz, external, external divided, external reference clock, PXI reference clock
Clock impedance	50 Ohm / 1 MOhm
Trigger impedance	50 Ohm / 1 MOhm
Trigger mode	Channel, External, Software, Auto, Windows, Pulse, PXI Line[5..0], PXI Startrigger
Trigger level	1/1024 to 1023/1024 of input range (10 bit)
Trigger edge	rising edge, falling edge or both edges
Trigger pulsewidth	1 to 255 samples in steps of 1 sample
Memory depth	32 up to installed memory in steps of 32
Posttrigger	32 up to 128 M in steps of 32
Multiple Recording segmentsize	32 up to installed memory / 2 in steps of 32

## Possibilities and options

### PXI bus

The PXI bus (PCI eXtension for instrumentation) offers a variety of additional standard possibilities for synchronising different components in one system. It is possible to connect several Strategic Test cards with each other or to connect a Strategic Test card with cards of other manufacturers.

### PXI reference clock

The card is able to use the 10 MHz reference clock that is supplied by the PXI system. Enabled by software the PXI reference clock is fed into the on-board PLL. This feature allows the cards to run with a fixed phase relation.

### PXI trigger

The UX cards support star trigger as well as the PXI trigger bus. Using a simple software command one or more trigger lines can be used as trigger source. This feature allows easy setup of OR connected triggers from different cards.

### Input impedance

All inputs could individually be switched by software between 50 Ohm and 1 MOhm input impedance. If using fast signals and high sampling rates or have 50 Ohm cable impedance the use of the 50 Ohm termination is recommended to minimise noise and signal reflections. If using weak signal sources or standard probes the use of the 1 MOhm termination is helpful.

### Ring buffer mode

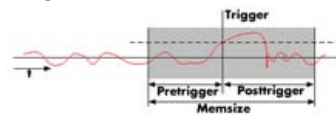

The ring buffer mode is the standard mode for all oscilloscope boards. Data is written in a ring memory of the board until a trigger event is

detected. After the event the posttrigger values are recorded. This allows the user to record events both before and after the trigger:  $\text{Pretrigger} = \text{Memsize} - \text{Posttrigger}$ .

### FIFO mode

The FIFO mode is designed for continuous data transfer between measurement board and PC memory (up to 100 MB /s) or hard disk (up to 50 MB/s). The control of the data stream is done automatically by the driver on interrupt request.

### Channel trigger

The data acquisition boards offer a wide variety of trigger modes. Besides the standard level and edge triggers known from oscilloscopes, it's also possible to define a window trigger. All trigger modes can be combined with the pulsewidth trigger. This makes it possible to trigger on signal errors like too long or too short pulses.

### External trigger I/O

All boards can be triggered using an external TTL signal. It's possible to use positive or negative edge also in combination with a programmable pulse width. A software trigger event can, when activated by software, be routed to the trigger connector to start external instruments.

### Pulse width

Defines the minimum or maximum width that a trigger pulse must have to generate a trigger event. Pulse width can be combined with channel trigger, pattern trigger and external trigger.

### Multiple Recording

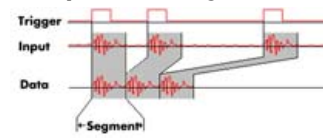

The Multiple Recording option allows the recording of several trigger events without restarting the hardware. This enables very fast repetition rates to be achieved. The on-board memory is divided in several segments of same size. Each of them is filled with data if a trigger event occurs.

### Gated Sampling

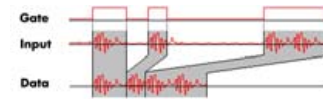

The Gated Sampling option allows data recording controlled by an external gate signal. Data is only recorded if the gate signal has a programmed level.

### External clock I/O

Using a dedicated connector a sampling clock can be fed in from an external system. It's also possible to output the internal sampling clock to synchronise external equipment to this clock.

### Reference clock

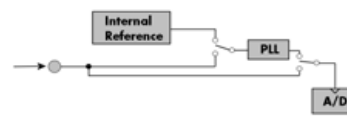

The option to use a precise external reference clock (normally 10 MHz) is necessary to synchronise the board for high-quality measurements with external equipment (like a signal source). It's also possible to enhance the quality of the sampling clock in this way.

The driver automatically generates the requested sampling clock from the fed in reference clock.

### Digital inputs

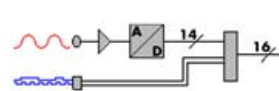

This option provides additional synchronous digital channels phase-stable with the analog data. When the option is installed there are 2 additional digital inputs for every analog A/D channel.

## Technical Data

Resolution	14 bit	Dimension	160 mm x 233 mm (Standrad 6U)
Differential linearity error	± 0.5 LSB typ. (ADC)	Width (Standard)	1 slot
Integral linearity error	± 1 LSB typ (ADC)	Width (with digital inputs)	2 slots
Multi: Trigger to 1st sample delay	fixed	Width (with star hub option)	2 slots
Multi: Recovery time	< 20 samples	Analogue Connector	3 mm SMB male
ext. Trigger accuracy	1 Sample	Digital Connector	40 pol half pitch (Hirose FX2 series)
int. Trigger accuracy	1 Sample	Digital Inputs delay to analog sample	-6 samples
Ext. clock: delay to internal clock	42 ns ± 2 ns	Overvoltage protection (range ≤ ±1 V)	±5 V
input signal with 50 W termination	max 5 V rms	Overvoltage protection (range > ±1 V)	±50 V
Trigger output delay	1 Sample	Warm up time	10 minutes
Input impedance	50 Ohm / 1 MOhm    25 pF	Operating temperature	0°C - 50°C
Crosstalk 1 MHz sine signal 50 Ohm	< -80 dB	Storage temperature	-10°C - 70°C
Crosstalk 1 MHz sine signal 1 MOhm	< -65 dB	Humidity	10% to 90%
Min internal clock	1 kS/s	Zero offset error	adjustable by user
Min external clock	500 kS/s	Gain error	< 1 % of full scale
		Power consumption 3.3 V @ full speed	max. 1.05 A (3.5 Watt)
		Power consumption 5 V @ full speed	max. 1.06 A (5.3 Watt)
Trigger input: Standard TTL level	Low: -0.5 V > level < 0.8 V High: 2.0 V > level < 5.5 V Trigger pulse must be valid ≥ 2 clock periods.	Clock input: Standard TTL level	Low: -0.5 V > level < 0.8 V High: 2.0 V > level < 5.5 V Rising edge. Duty cycle: 50% ± 5%
Trigger output	Standard TTL, capable of driving 50 Ohm. Low < 0.4 V (@ 20 mA, max 64 mA) High > 2.4 V (@ -20 mA, max -48 mA) One positive edge after the first internal trigger	Clock output	Standard TTL, capable of driving 50 Ohm Low < 0.4 V (@ 20 mA, max 64 mA) High > 2.4 V (@ -20 mA, max -48 mA)

	UX.4020 UX.4021	UX.4030 UX.4031
max internal clock	20 MS/s	50 MS/s
max external clock	20 MS/s	50 MS/s
-3 dB bandwidth	> 10 MHz	> 25 MHz
Zero noise level at 50 Ohm	< 2.1 LSB rms	< 2.9 LSB rms

## Dynamic Parameters

	UX.4020 UX.4021	UX.4030 UX.4031
Test - Samplerate	20 MS/s	50 MS/s
Testsignal frequency	1 MHz	1 MHz
SNR (typ)	> 69.7 dB	> 66.9 dB
THD (typ)	< -71.5 dB	< -70.8 dB
SFDR (typ), incl harm.	> 79.8 dB	> 73.8 dB
SINAD (typ)	> 67.5 dB	> 65.4 dB
ENOB (based on SINAD)	> 10.9	> 10.6

Dynamic parameters are measured at ± 1 V input range (if no other range is stated) and 50 Ohm termination with the samplerate specified in the table. Measured parameters are averaged 20 times to get typical values. Test signal is a pure sine wave of the specified frequency with > 99% amplitude. SNR and RMS noise parameters may differ depending on the quality of the used PC. SNR = Signal to Noise Ratio, THD = Total Harmonic Distortion, SFDR = Spurious Free Dynamic Range, SINAD = Signal Noise and Distortion, ENOB = Effective Number of Bits. For a detailed description please see application note 002.

## Order information

All cards are supplied with two year hardware warranty, lifetime technical support and lifetime software updates. These include future Windows / Linux version drivers.

Order No	Description	Order No	Description
UX4020	UX.4020 with 8 MSample memory and drivers/SBench 5.x	UX4000-16M	Option: 16 MSample memory instead of 8 MSample standard mem
UX4021	UX.4021 with 8 MSample memory and drivers/SBench 5.x	UX4000-32M	Option: 32 MSample memory instead of 8 MSample standard mem
UX4030	UX.4030 with 8 MSample memory and drivers/SBench 5.x	UX4000-64M	Option: 64 MSample memory instead of 8 MSample standard mem
UX4031	UX.4031 with 8 MSample memory and drivers/SBench 5.x	UX4000-up	Additional handling costs for later memory upgrade
UX4000-mr	Option Multiple Recording: Memory segmentation	UX4000-dl	DASYLab driver for UX.4000 series
UX4000-gs	Option Gated Sampling: Gate signal controls acquisition	UX4000-hp	VEE driver for UX.4000 series
UX4000-dig	Additional 4 synchronous digital inputs per channel, incl. cable	UX4000-lv	LabVIEW driver for UX.4000 series
		UF/UC/UX-ml	MATLAB driver for all UF/UC/UX series.
Cab-3f-9m-80	Adapter cable: SMB female to BNC male 80 cm	Cab-3f-9f-80	Adapter cable: SMB female to BNC female 80 cm
Cab-3f-9m-200	Adapter cable: SMB female to BNC male 200 cm	Cab-3f-9f-200	Adapter cable: SMB female to BNC female 200 cm

technical changes and printing errors possible

